

P-27 DUAL

Jan.27.2016

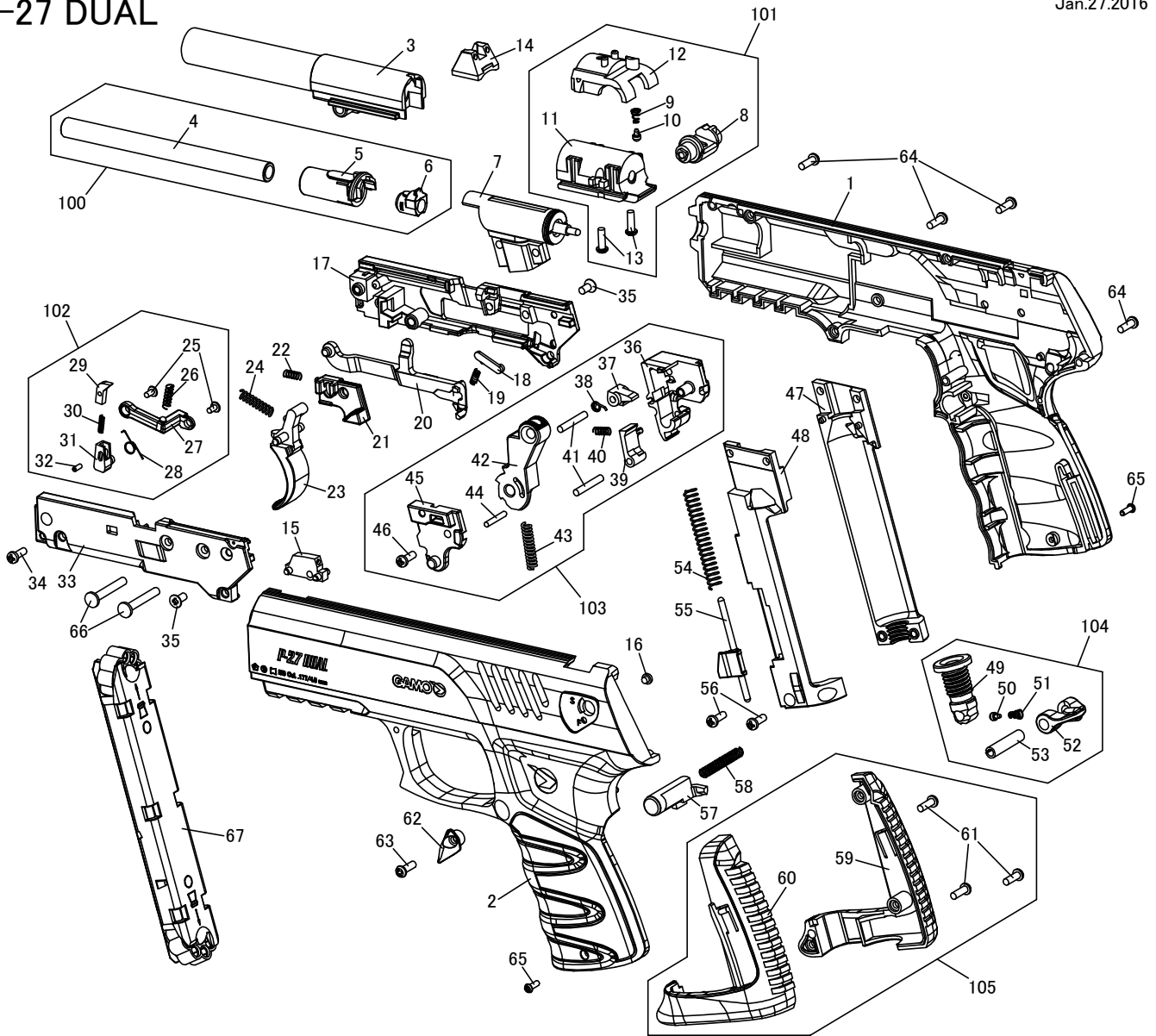

- | | | |
|--------------------------------------|---------------------------------|---|
| 1. Frame Right | 24. Trigger Spring | 47. Puncture Frame Right |
| 2. Frame Left | 25. Nail Arm Screw | 48. Puncture Frame Left |
| 3. Outer Barrel | 26. Nail Arm Spring | 49. Puncture Adjuster Screw |
| 4. Inner Barrel | 27. Nail Arm | 50. Puncture Screw Click Plunger |
| 5. Barrel Base | 28. Nail Base Spring | 51. Puncture Screw Click Plunger Spring |
| 6. Chamber Sleeve | 29. Nail | 52. Puncture Adjuster Screw Knob |
| 7. Valve Assembly | 30. Nail Spring | 53. Puncture Screw Pin |
| 8. Safety | 31. Nail Base | 54. Magazine Release Spring |
| 9. Safety Lever Click Plunger Spring | 32. Nail Pin | 55. Magazine Release Bar |
| 10. Safety Lever Click Plunger | 33. Mechanism Frame Left | 56. Puncture Frame Screw |
| 11. Cylinder Block | 34. Mechanism Frame Front Screw | 57. Magazine Catch |
| 12. Cylinder Block Cover | 35. Mechanism Frame Rear Screw | 58. Magazine Catch Spring |
| 13. Cylinder Block Screw | 36. Hammer Base Right | 59. Grip Bottom Right |
| 14. Rear Sight | 37. Hammer Block | 60. Grip Bottom Left |
| 15. Front Sight | 38. Hammer Block Spring | 61. Grip Bottom Screw |
| 16. Red Dot | 39. Sear | 62. Safety Lever |
| 17. Mechanism Frame Right | 40. Sear Spring | 63. Safety Lever Screw |
| 18. Trigger Bar Plunger | 41. Hammer Base Pin | 64. Frame Screw A |
| 19. Trigger Bar Plunger Spring | 42. Hammer | 65. Frame Screw B |
| 20. Trigger Bar | 43. Hammer Spring | 66. Valve Pin |
| 21. Nail Arm Lift | 44. Hammer Pin | 67. Magazine Assembly |
| 22. Nail Arm Lift Spring | 45. Hammer Base Left | |
| 23. Trigger | 46. Hammer Base Screw | |